

Models

AV-2, AV-2P, AV-2PBP, AV-2ST, AV-2BP, AV-5,
AV-5P, AV-5PTE, AV-5ST, AV-10ST, AV-15,
AV-15PTE, AV-15ST, AV-15P, AV-15ST, AV-55,
AV-55P, AV-55P-CND



HEPA Filtered Vaccums

Manual No. AV0001
(Rev 4 April 2009)

Operating Manual



NOTE: Electric motors are UL, CUL, and CSA listed. Optional voltage and Hertz available. Consult customer service for details.

AIRSYSTEMSINTERNATIONAL, INC.

829 Juniper Crescent, Chesapeake, Va. , 23320

Telephone (757) 424-3967

Toll Free 1-800-866-8100

Fax No. (757) 424-5348

<http://www.airsystems.com>

e-mail: sales@airsystems.com

OVERVIEW

IMPORTANT SAFETY INFORMATION IS ENCLOSED.

Read and follow all instructions before using these vacuums. Please read them carefully since failure to follow these precautions could result in injury. When using electrical equipment basic safety precautions should always be followed.



Warning: *The basic vacuum is designed for dry/damp pickup. Do not attempt to pickup liquids under any condition without using an automatic shut off assembly.*

When using the electrical vacuum, basic precautions should always be followed. The following warnings should be adhered to reduce the risk of fire, electrical shock or injury:

1. DO NOT leave vacuum when plugged in. Unplug from outlet when not in use and before servicing.
2. Electric shock could occur if used on wet surfaces. DO NOT expose to rain. Store indoors.
3. Use only as described in this manual. Use only Air Systems' recommended attachments and replacement filters.
4. DO NOT use with damaged cord or plug. If vacuum is not working as it should because it has been dropped, damaged, left outdoors, or dropped into water, return it to Air Systems for servicing. Call 1-800-866-8100 for a return authorization number. **Do not return contaminated vacuums.**
5. DO NOT pull or carry by cord or use cord as a handle. Keep cord away from heated surfaces.
6. DO NOT unplug by pulling on cord. To unplug, grasp the plug, not the cord.
7. DO NOT handle plug or vacuum with wet hands.
8. DO NOT put any objects into motor openings. Do not use with openings blocked.
9. DO NOT vacuum up anything that is burning or smoking, such as cigarettes, matches, or hot ashes.
10. For toxic dusts, do not use without paper filter bag, intermediate filter, and HEPA filter properly installed.
11. DO NOT use in areas where flammable or combustible liquids, such as gasoline, may be present.
12. DO NOT use where oxygen or anesthetic gases are used.
13. DO NOT use an extension cord unless absolutely necessary. If an extension cord is used, then wire size must be 14/3 or larger and should not exceed 50 feet in length. Extension cord must be a three-wire type to insure "grounding" protection.
14. Replace damaged or worn parts immediately with genuine original equipment parts to maintain safety and to protect your limited warranty.

Note: *Absolute HEPA filtered vacuums meet ANSI Standard Z9.2-1979 with UL-586 tested and labeled HEPA filter.*

Absolute HEPA filtered vacuums are designed for industrial plants, clean rooms, nuclear plants or wherever dangerous air or dust pollutants must be removed. Triple filtration provides 99.97% efficiency in retention of particles down to 0.3 microns in size. Absolute filters are a necessity where an extremely high level of cleanliness is required for the removal of asbestos, lead, and other toxic dusts. Each absolute filter at its final assembly, is tested and labeled by the manufacturer to the latest industrial standards and specifically to the UL-586 standard. Precision testing is performed with thermally generated D.O.P. (Doctyl Phthalate) aerosol according to Mil-Standard 282. The test machinery is specially designed to assure the guaranteed efficiency of 99.97% on a particle size of 0.3 microns. Each absolute filter is individually tested and certified by the manufacturer, with a prominently displayed label showing results of the actual D.O.P. test.

3-STAGE HEPA FILTRATION SYSTEM

Stage 1

Totally enclosed double-ply paper filter bags with special fold-over self-adhesive seal patch. Throwaway bags are stenciled with caution instructions for disposal purposes. Paper bags produce filtration efficiency down to 5 microns.

Stage 2

Intermediate filter made of two plies of nonwoven media. The filter has a sewn-in elastic top to fit around the HEPA filter. (Elastic is placed below rim of HEPA filter). When used with Stage 1 paper bag, filtration efficiency is down to 2 microns.

Stage 3

Certified absolute filter is constructed of a steel outer casing with filter media of high strength micro-fibered glass paper separated by corrugated aluminum sheeting that is entrapped in steel screening for protection against damage to media. The HEPA filter is designed to filter particles down to 0.3 microns. Absolute filter meets ANSI Standard Z9.2 and UL-586 Standard.

STEEL VACUUMS - DRY OPERATION

INITIAL SETUP

INSTALLATION OF HEPA FILTER ASSEMBLY

1. Remove vacuum from carton. Unsnap hold down clamps, remove motor head, HEPA filter, and carefully set aside.
2. Unpack 2-ply intermediate filters, 2-ply disposable paper filter bags, 6 mil (OSHA approved) poly bags, hose, and attachments from inside vacuum tank.
3. Arrange a 6 mil poly bag in the bottom of the vacuum tank. (See illustration of dry filter setup). Install a 2-ply disposable paper filter bag onto the inlet fitting by holding on to the free ends of cardboard attached to paper bag and pull it forward over the inlet fitting so that the cardboard is as close to the tank's wall as possible.
5. Place the 2-ply intermediate filter in position on top of tank and fold edge over outside of tank, overlapping it approximately one inch.
6. Insert HEPA filter, being careful not to move the 2-ply intermediate filter. The HEPA filter's sealing gasket must sit evenly on the tank's rim so that an air tight seal will be obtained.
7. Replace the motor head assembly on top of the HEPA filter, seated on top of the vacuum tank and resnap hold-down clamps.

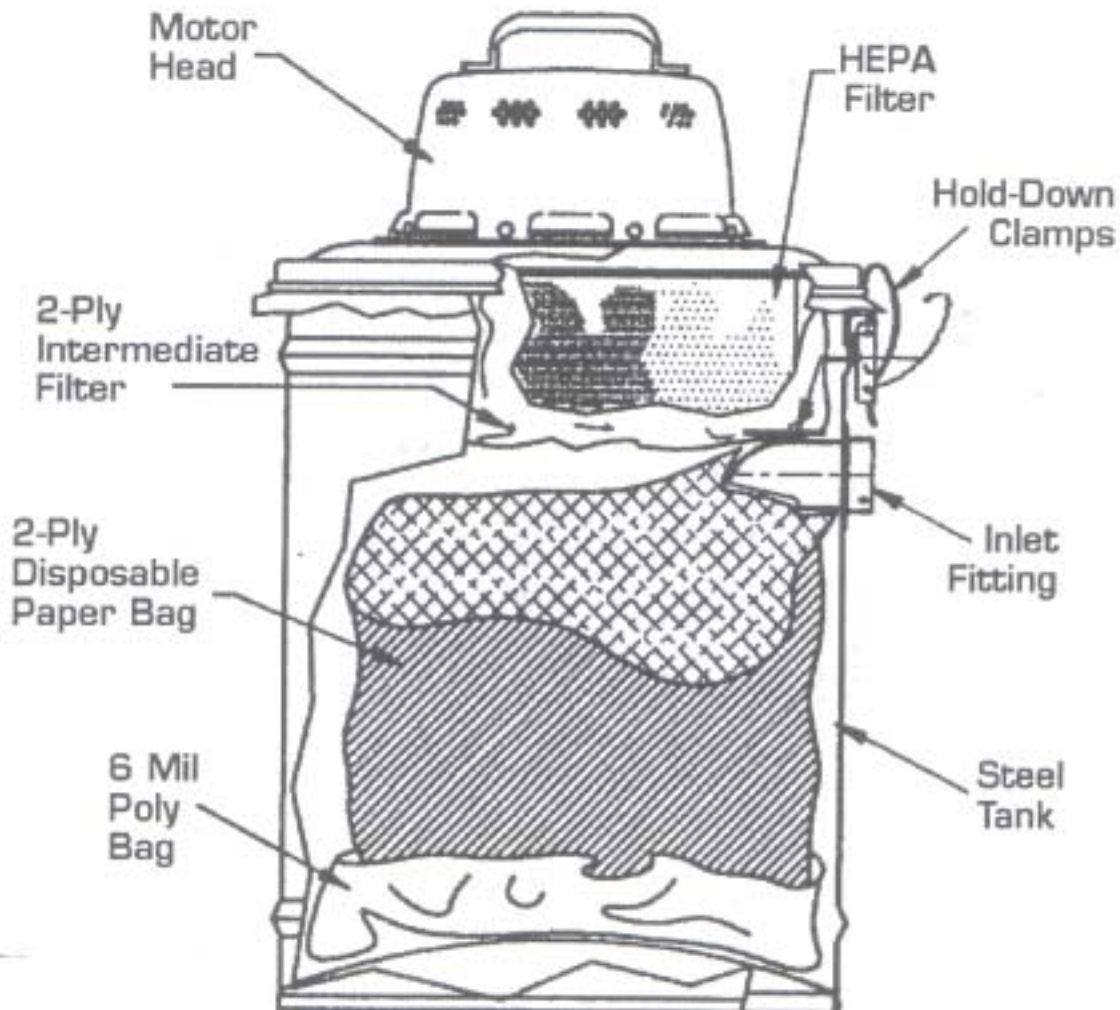

Note: To insure a snug fit, make sure that the area around the lid and top edge of vinyl sealing gasket is free of dirt and other foreign matter.

STEEL VACUUM - WET OPERATION (OPTIONAL)

INITIAL SETUP

In order to use this vacuum for wet pickup you must install a wet pickup conversion kit, an optional accessory. The kit consists of a conversion adaptor, wet pickup adaptor and squeegee tool.

INSTALLATION OF WET CONVERSION ADAPTOR (OPTIONAL)

1. Carefully remove the motor head, HEPA filter, and 2-ply intermediate filter. Set aside.
2. Set the wet pickup adaptor on the tank's rim, next set the conversion adaptor on top of the wet pickup adaptor and snap down hold-down clamps.
3. Follow HEPA filter assembly installation instructions.

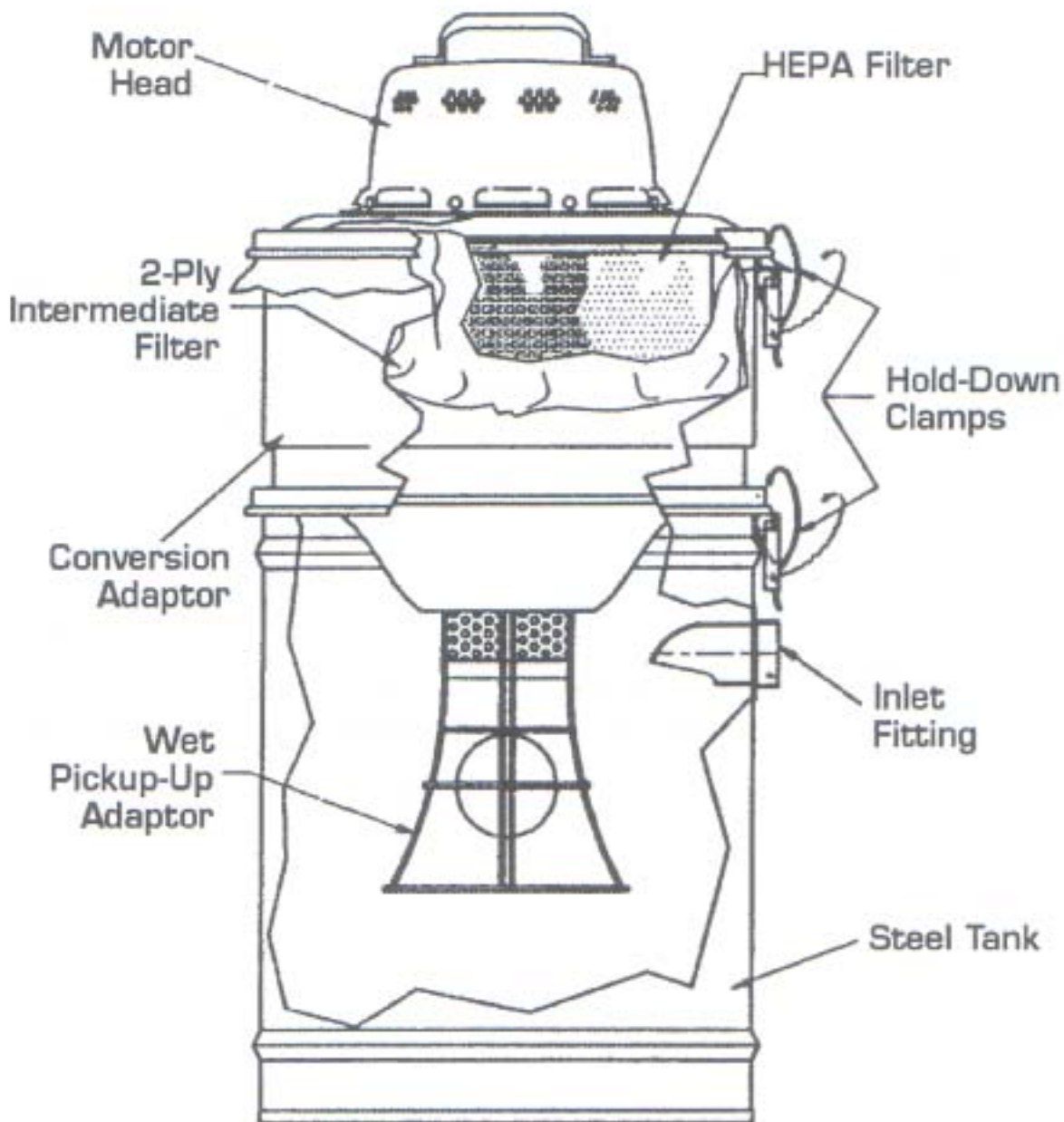

Note: To insure a snug fit, make sure that the area around the lid and top edge of vinyl sealing gasket is free of dirt and other foreign matter.

POLY TANK VACUUMS - DRY OPERATIONS

INITIAL SETUP

Poly tank hazardous vacuums are shipped in 2 cartons and require a conversion adaptor for the HEPA filter assembly to set in.

1. Open the larger carton and remove the vacuum. Unsnap hold-down clamps, and lift off the motor head, pancake style filter, and carefully set aside.
2. Unpack the 2-ply disposable bags, 6 mil (OSHA approved) poly bags, attachments, and hose from inside vacuum tank.
3. Arrange a 6 mil poly in the bottom of the vacuum tank. (See illustration of Dry Filter Setup).
4. Install a 2-ply disposable paper filter bag on to inlet fitting by holding on to the free ends of cardboard attached to the paper bag and pull forward over inlet fittings so that the cardboard is as close to the tank's wall as possible. Set pancake style filter on the vacuum tank rim.
5. Unpack the second carton and place conversion adaptor on top of pancake filter and engage hold-down clamps.
6. Place the 2-ply intermediate filter in position on top of the conversion adaptor and fold edge over outside of tank, overlapping it approximately one inch.
7. Insert HEPA filter, being careful not to move the 2-ply intermediate filter. The HEPA filter's sealing gasket must sit evenly on the tank's rim so that an air tight seal will be obtained.
8. Replace the motor head assembly on top of the HEPA filter, seated on top of the vacuum tank.

Note: Never operate this vacuum without primary HEPA filter. The 2-ply disposable paper filter bag (for dry operation) or wet pickup adapter (for wet operation) and NEVER without a 2-ply intermediate filter in position. Motor damage, loss of operation efficiency and circulation of hazardous materials into the work area will take place.

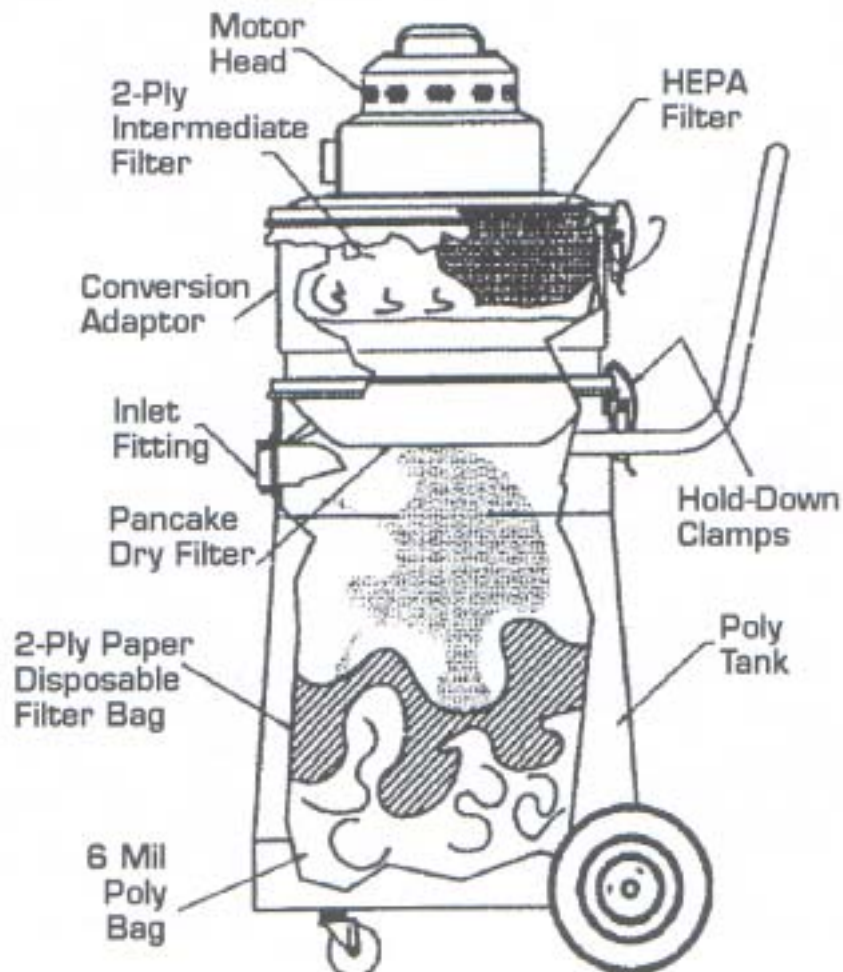

POLY TANK VACUUMS - WET OPERATIONS

INITIAL SETUP

In order to use this vacuum for wet pickup you must replace the pancake filter with a wet pickup adaptor. Wet/dry poly models are shipped the adaptor. If your unit was ordered for dry pickup only you must order the adaptor. See parts section for ordering information.

1. Carefully remove the motor head, HEPA filter, 2-ply intermediate filter, conversion adaptor, and pancake filter. Set aside.
2. Set the wet pickup adaptor on the tank's rim, next set the conversion adaptor on top of the wet pickup adaptor and snap down hold-down clamps.
3. Follow HEPA Filter Assembly installation instructions above.

Note: Never operate this vacuum without primary HEPA filter. The 2-ply disposable paper filter bag (for dry operation) or wet pickup adaptor (for wet operation) and NEVER without a 2-ply intermediate filter in position. Motor damage, loss of operation efficiency and circulation of hazardous materials into the work area will take place.

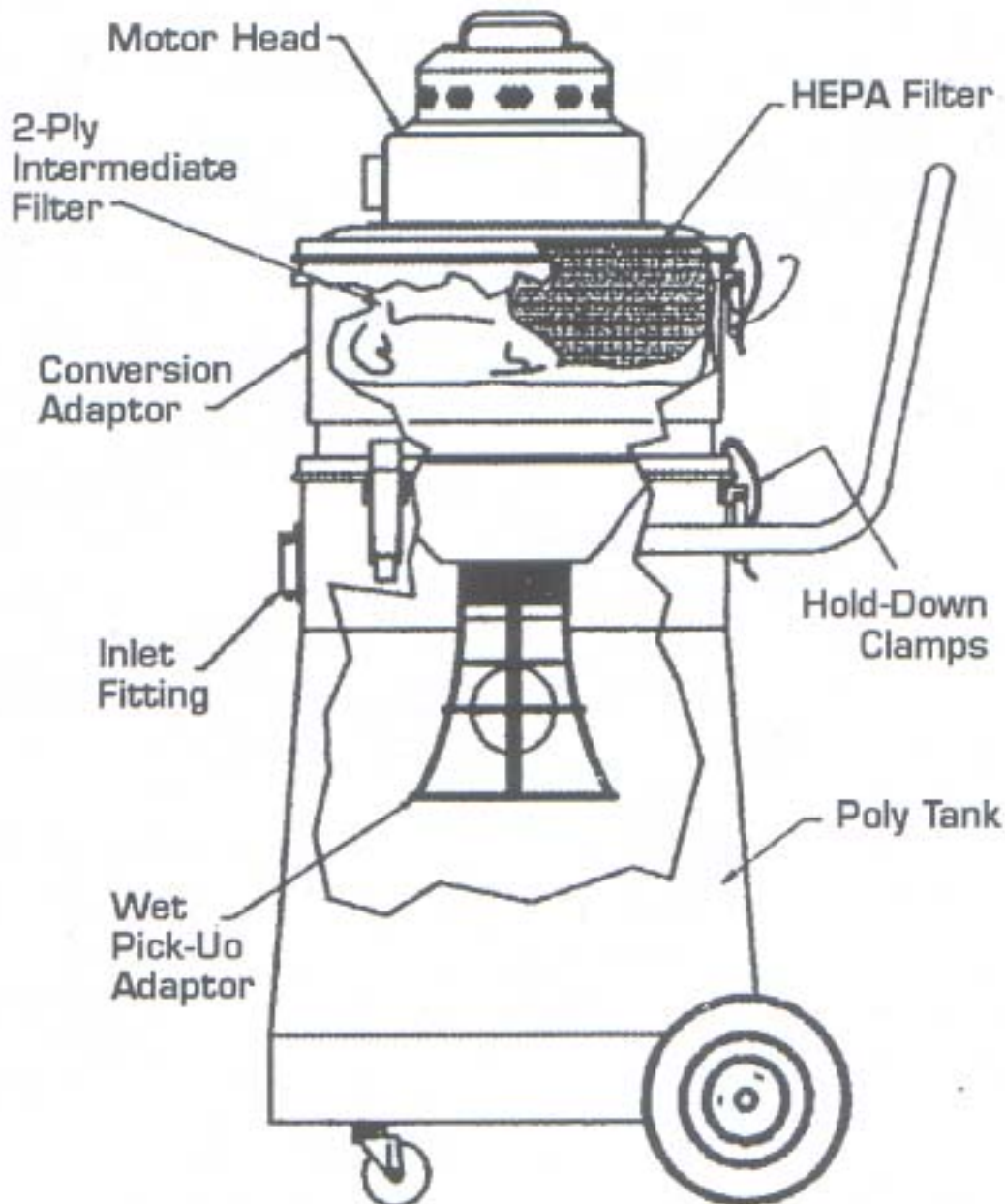

PNEUMATIC MOTOR VERSIONS

INITIAL SETUP

1. Secure a compressed air source capable of supplying a minimum 80 - 100 psi and 70cfm flow rate . A minimum hose I.D. of a 1/2" is required to connect to a 1/2" Industrial Inter change style male plug.
2. The air motor has no moving parts and requires to service if the air source is clean air, free of oil and water. An "on-off" valve is provided to regulate flow to the air motor.



Warning: *Operating this air motor above 100psi may cause implosion of the metal can. Do not tamper with the relief valve supplied internally with the air motor.*

FILTER MAINTENANCE

"WHEN TO CHANGE FILTERS"



Caution: *Always unplug vacuum from power source before changing filters*

2-Ply Disposable Paper Filter Bag

When the 2-ply disposable paper bag is full, it must be replaced. Excessive over filling of this bag makes it difficult to remove from the vacuum tank and can result in breakage and spills.

2-Ply Intermediate Filter

The 2-ply intermediate filter should be replaced with every fifth (5) change of paper bags or whenever there is damage or visible collection of debris on the outside of the filter.

HEPA Filter

Replace the HEPA filter when loss of vacuum (suction) continues to occur after you have checked for an obstruction in the hose or wand, installed a new 2-ply-disposable paper filter bag, and 2-ply intermediate filter.



Caution: *Hazardous materials must be disposed of properly. NEVER throw contaminated debris in your usual trash receptacle. Place debris in a 6 mil poly bag or container marked with HAZARDOUS MATERIALS warning and dispose or in accordance with your local hazardous waste regulations.*

EQUIPMENT MAINTENANCE

Contact distributor or manufacturer to receive written authorization for return of vacuum. Transportation charges to the service location must be paid by the purchaser. Warranty is void if electrical components and motor are serviced by non-factory service personnel. The use of non-certified parts can result in possible safety hazards and void UL certifications. To insure warranty, please return the enclosed warranty registration card within 10 days of purchase. For service, call Air Systems' customer service department at 1-800-866-8100.

VACUUM FILTER SETUP AND INSTALLATION

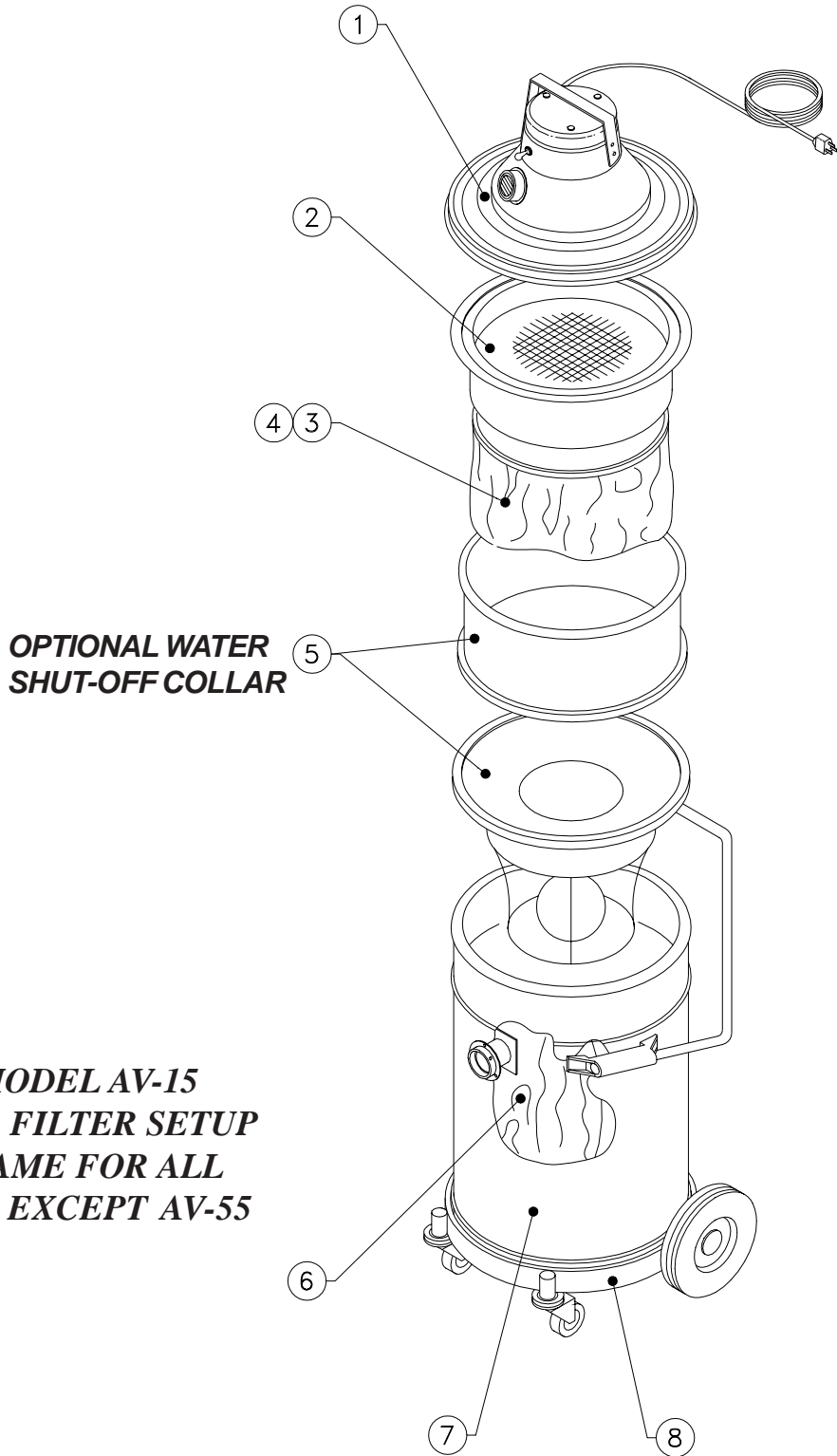

| ITEM # | DESCRIPTION | AV-2 | AV-2P | AV-5 | AV-5PTE | AV-5P | AV-15 | AV-15PTE | AV-15P | AV-55P |
|--------|-----------------------------------|--------|---------|----------|---------|----------|----------|----------|----------|----------|
| 1 | MOTOR HEAD ASSEMBLY | AV-2MH | AV-2PMH | AV-5MH | AV-5MH | AV-5PMH | AV-15MH | AV-15MH | AV-15PMH | AV-15PMH |
| 2 | HEPA FILTER | AV-2H | AV-2H | AV-5H | AV-5H | AV-5H | AV-15H | AV-15H | AV-15H | AV-15H |
| 3 | DISPOSABLE INTERMEDIATE FILTER | AV-5I | AV-5I | AV-5I | AV-5I | AV-5I | AV-15I | AV-15I | AV-15I | AV-15I |
| 4 | OPTIONAL DACRON FILTER (WASHABLE) | AV-5D | AV-5D | AV-5D | AV-5D | AV-5D | AV-15D | AV-15D | AV-15D | AV-15D |
| 5 | OPTIONAL AUTO SHUT-OFF ASSEMBLY | N/A | N/A | AV-5WP | AV-5WP | AV-5WP | AV-15WP | AV-15WP | AV-15WP | AV-15WP |
| 6 | RECOVERY BAG (DISPOSABLE) | AV-2B | AV-2B | AV-5B | AV-5B | AV-5B | AV-15B | AV-15B | AV-15B | AV-15B |
| 7 | RECOVERY CAN | AV-2C | AV-2C | AV-33495 | AV-5CP | AV-33495 | AV-15CSS | AV-15CP | AV-15CSS | AV-15CSS |
| 8 | DOLLY | N/A | N/A | N/A | N/A | N/A | AV-15DA | AV-15DA | AV-15DA | AV-55DD |

VACUUM FILTER SETUP MODEL AV-2 & AV-2BP

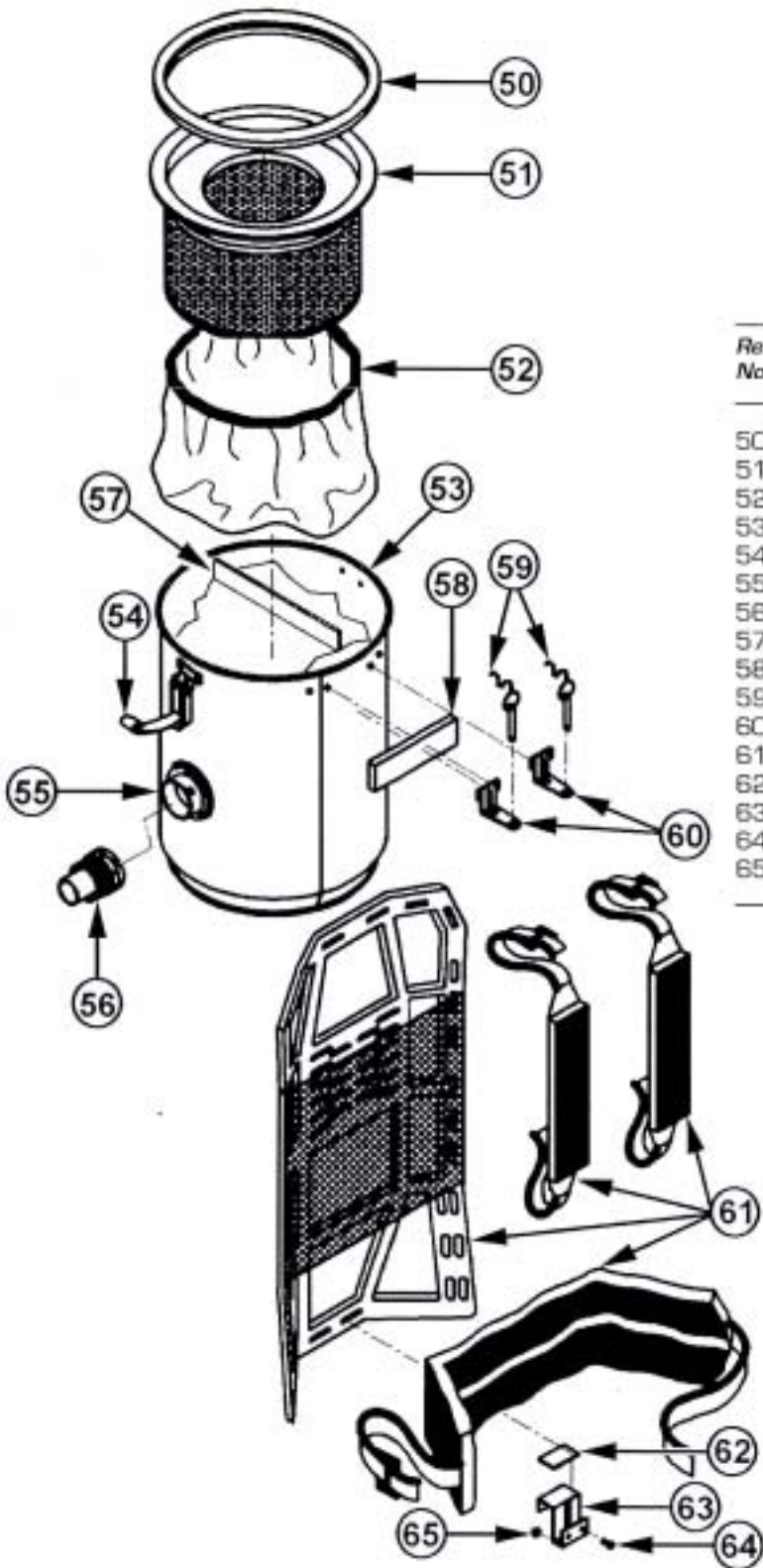

| Ref No | Part Description | Qty | Part No |
|--------|-------------------------------------|-----|-----------|
| 50 | HEPA Filter Gasket | 1 | 302392 |
| 51 | HEPA Filter Assembly | 1 | 302376 |
| 52 | 2 Ply Intermediate Filter (2/Pk) | 1 | AV-5I |
| 53 | Stainless Steel Tank w/Clamps | 1 | AV-2C |
| 54 | Holddown Clamps | 2 | AV-358312 |
| 55 | Inlet Assembly | 1 | AV-15FMA |
| 56 | 1 1/2" Swivel Connector | 1 | AV-101 |
| 57 | 2-Ply Disposable Filter Bags (5/Pk) | 1 | AV-2B |
| 58 | Flat Gasket | 1 | 303607 |
| 59 | Speed Pin Assembly | 2 | 385182 |
| 60 | Tank Frame Clips | 2 | 303631 |
| 61 | Frame w/Straps & Harness | 1 | 302902 |
| 62 | Bottom Pad | 1 | 303615 |
| 63 | Frame Mounting Clip | 1 | 421731 |
| 64 | #10-24 X 3/4" Screw | 2 | 337315 |
| 65 | #10-24 Hex Nut | 2 | 331201 |

MODEL AV-2 MOTOR HEAD PARTS LIST & AV-2BP

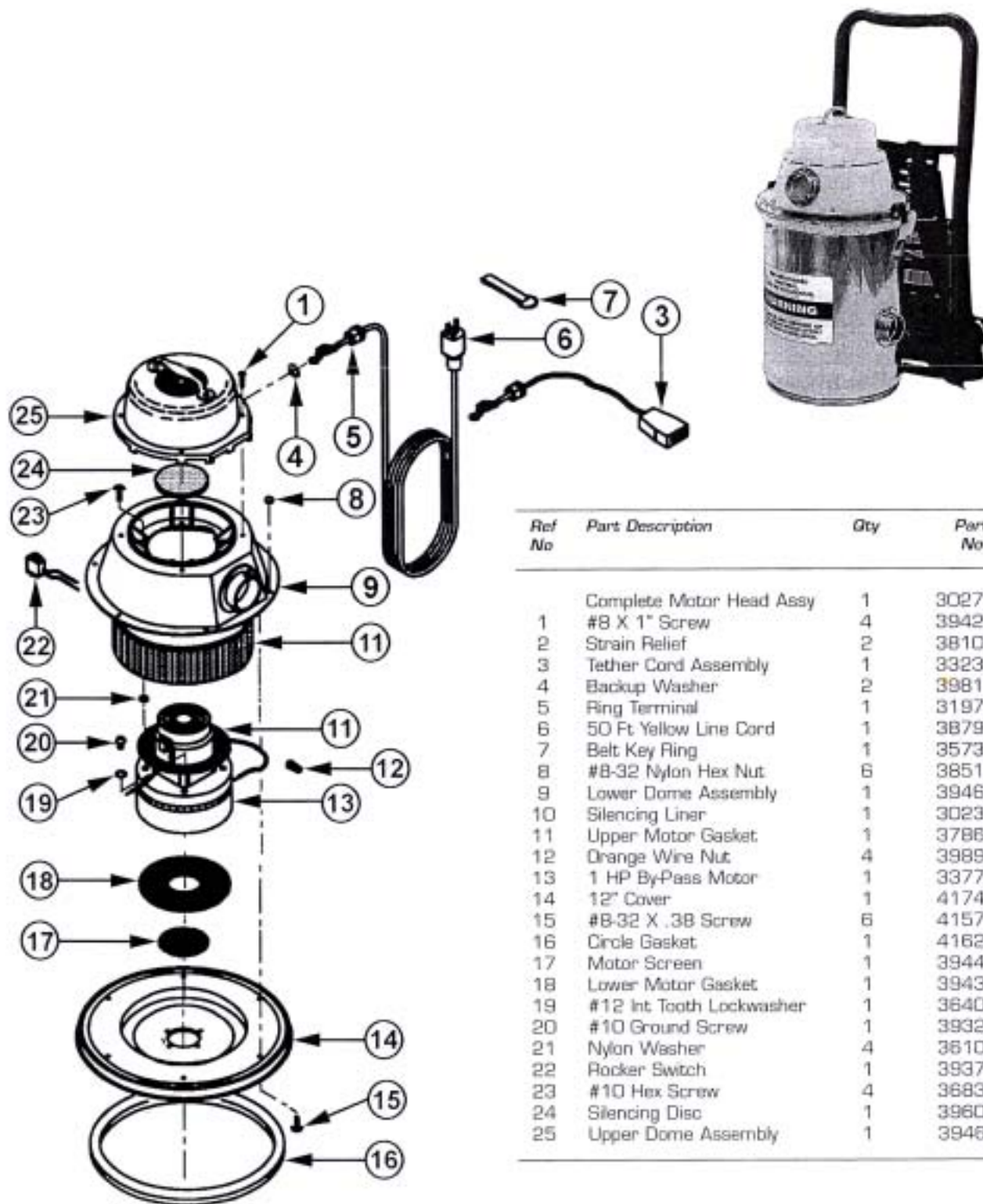

| Ref No | Part Description | Qty | Part No |
|--------|--------------------------|-----|---------|
| | Complete Motor Head Assy | 1 | 302783 |
| 1 | #8 X 1" Screw | 4 | 394270 |
| 2 | Strain Relief | 2 | 381063 |
| 3 | Tether Cord Assembly | 1 | 332313 |
| 4 | Backup Washer | 2 | 398187 |
| 5 | Ring Terminal | 1 | 319724 |
| 6 | 50 Ft. Yellow Line Cord | 1 | 387916 |
| 7 | Belt Key Ring | 1 | 357316 |
| 8 | #8-32 Nylon Hex Nut | 6 | 385158 |
| 9 | Lower Dome Assembly | 1 | 394610 |
| 10 | Silencing Liner | 1 | 302368 |
| 11 | Upper Motor Gasket | 1 | 378607 |
| 12 | Orange Wire Nut | 4 | 398985 |
| 13 | 1 HP By-Pass Motor | 1 | 337757 |
| 14 | 12" Cover | 1 | 417432 |
| 15 | #8-32 X .38 Screw | 6 | 415758 |
| 16 | Circle Gasket | 1 | 416290 |
| 17 | Motor Screen | 1 | 394432 |
| 18 | Lower Motor Gasket | 1 | 394300 |
| 19 | #12 Int Tooth Lockwasher | 1 | 364037 |
| 20 | #10 Ground Screw | 1 | 393258 |
| 21 | Nylon Washer | 4 | 381054 |
| 22 | Rocker Switch | 1 | 393754 |
| 23 | #10 Hex Screw | 4 | 368385 |
| 24 | Silencing Disc | 1 | 396028 |
| 25 | Upper Dome Assembly | 1 | 394602A |

AV-2P & AV-2PBP REPLACEMENT PARTS

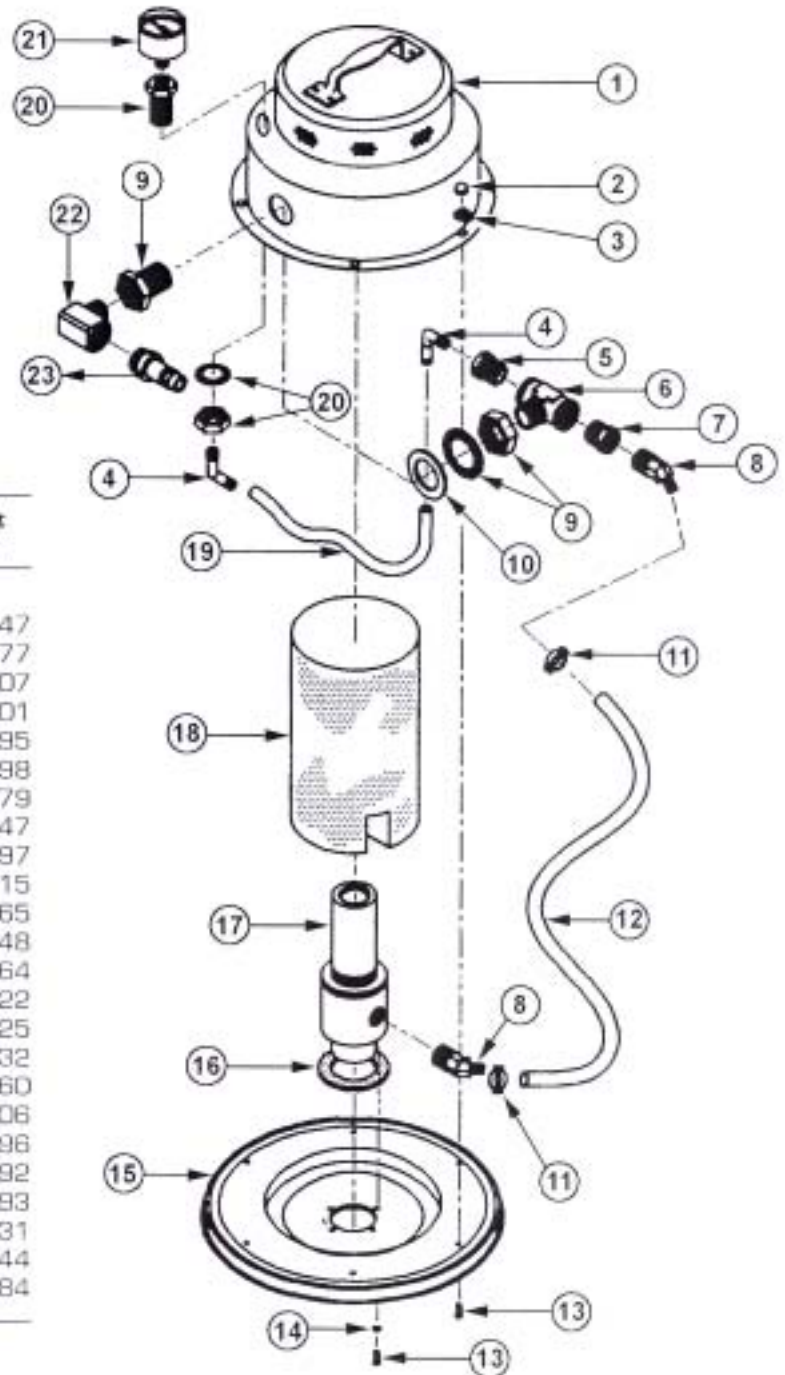
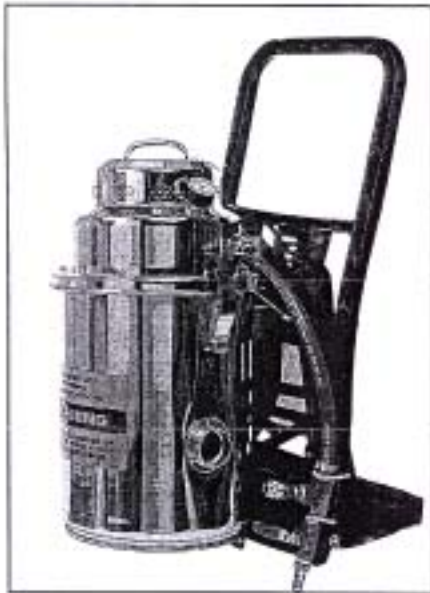

| Ref No | Part Description | Qty | Part No |
|--------|------------------------------|-----|---------|
| | 12" Air-Operated Head Assy | 1 | 325147 |
| 1 | Dome Assembly | 1 | 304077 |
| 2 | #10-24 Acorn Nut | 6 | 359807 |
| 3 | #10-24 Hex Nut w/Lockwasher | 6 | 331201 |
| 4 | 1/2" NPT Elbow Fitting | 2 | 304395 |
| 5 | 1/2" to 1/4" Reducer | 1 | 304298 |
| 6 | 1/2" Tee Fitting | 1 | 304379 |
| 7 | 1/2" to 3/8" Reducer | 1 | 359947 |
| 8 | 3/8" Male w/Barber Connector | 2 | 304697 |
| 9 | 1/2" NPT Bulk Head Assembly | 1 | 304115 |
| 10 | SS Reinforcing Ring | 1 | 374865 |
| 11 | 5/8" Hose Clamp | 2 | 304948 |
| 12 | 3/8" High Pressure Hose | 1 | 304964 |
| 13 | #10-24 X 1/2" Screw | 10 | 341622 |
| 14 | #10 Lockwasher | 4 | 380725 |
| 15 | 12" Cover Assembly | 1 | 417432 |
| 16 | Flat Gasket | 1 | 416460 |
| 17 | Venturi | 2 | 304506 |
| 18 | Muffler | 1 | 306096 |
| 19 | 1/4" OD Tubing | 1 | 304492 |
| 20 | 1/2" NPT Bulk Head Assembly | 1 | 304093 |
| 21 | 0-200 Pressure Gauge | 1 | 304131 |
| 22 | 1/2" Brass Elbow Fitting | 1 | 325244 |
| 23 | 1/2" GDC Male Fitting | 1 | 304484 |

VACUUM FILTER SETUP MODEL AV-55 & AV-55P

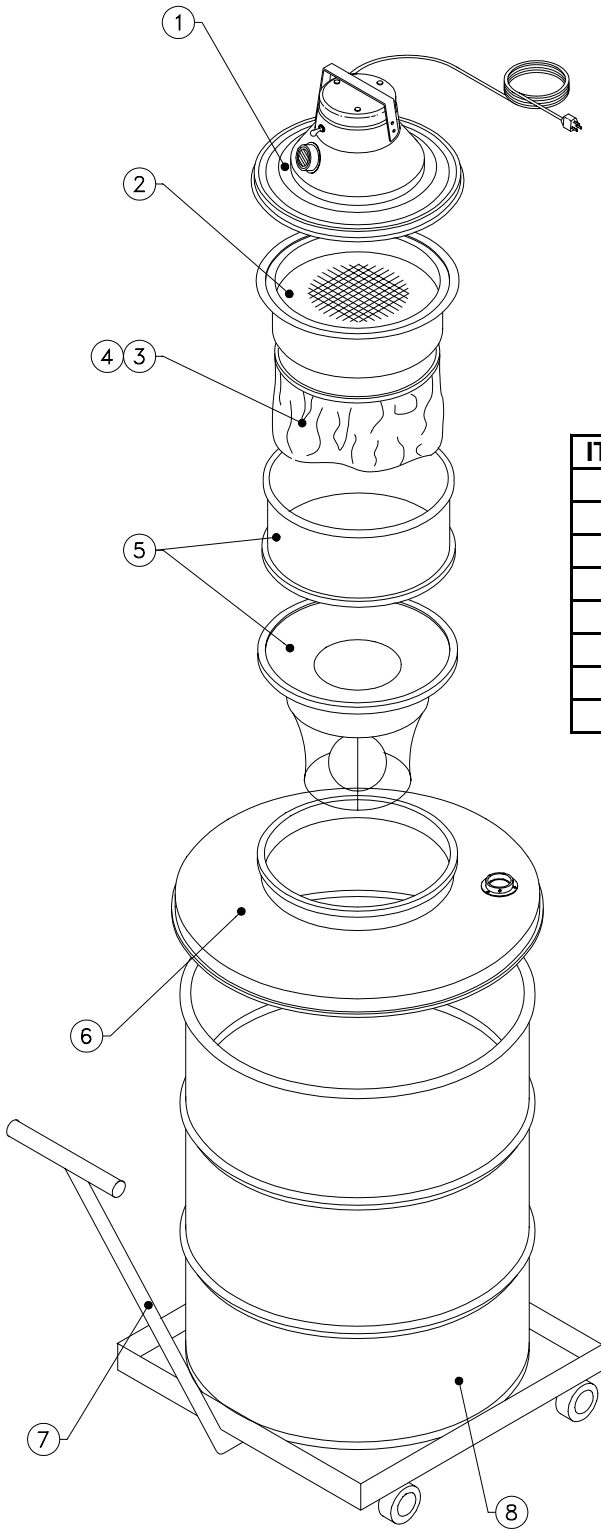

| ITEM # | DESCRIPTION | AV-55 | AV-55P |
|--------|-----------------------------------|---------|----------|
| 1 | MOTOR HEAD ASSEMBLY | AV-15MH | AV-15PMH |
| 2 | HEPA FILTER | AV-15H | AV-15H |
| 3 | DIPOSABLE INTERMEDIATE FILTER | AV-15I | AV-15I |
| 4 | OPTIONAL DACRON FILTER (WASHABLE) | AV-15D | AV-15D |
| 5 | OPTIONAL AUTO SHUT-OFF ASSEMBLY | AV-15WP | AV-15WP |
| 6 | 55 GAL. DRUM LID ADAPTER | AV-55DL | AV-55DL |
| 7 | DRUM DOLLY | AV-55DD | AV-55DD |
| 8 | 55 GAL. STEEL DRUM | AV-55DH | AV-55DH |

WARNING

STATIC CONDUCTIVE HOSE

Static conductive hose is composed of a proprietary static conductive compound. When used with the proper static conductive cuffs and accessories and properly connected to a properly grounded vacuum system, will serve as a mean to conduct or dissipate static electricity. Verification of system integrity is the sole responsibility of the user. Failure by the user to verify system integrity could result in electrical shock, bodily injury and destruction or damaging of property. Depending on the application, particularly the property of the materials transported by the system, volume, bending, pressure, vacuum or prevailing conditions, the use of the hose may require frequent inspections. We recommend that inspections of the interior and exterior of the hose be performed at frequent intervals by the user related to the applicable risk factors. Hose or accessories indicating wear affecting the integrity of the system should be replaced before risk factors increase. We are not in a position to anticipate all of the conditions and factors involved in a particular application. Suitability of this hose for use in a particular application is the sole responsibility of the user. It is for this reason that the installer and end user of the system should conduct adequate testing of the hose for particular application prior to assembly or installation. We recommend to our purchaser that they advise end users of this warning. Failure to strictly follow this warning will void any and all press or implied warranties of fitness, merchantability, or functionality of the product.

WARRANTY

Your vacuum cleaner carries a limited warranty against defects in materials and workmanship from the date of delivery to the original purchaser for use of the product when operated and maintained as instructed. Motor warranty is two years, balance of unit is one year. This warranty does not cover normal wear and tear, external or internal finish, or carbon brushes (except if defective at time of original purchase). The warranty excludes damage resulting from accident, misuse, abuse, neglect, modification or alternation.

AV-55PCND CONDUCTIVE VACUUM



This 55 gallon drum vacuum is supplied complete with a cart, filters, motor, and accessories. Conductive hose is provided and will allow static charge buildup to pass to the recovery can and then to the ground wire. Aluminum tools should only be used and are provided to prevent sparking. The drum head is grounded to the 55 gallon drum. A ground wire and clamp must be attached to a grounded source in order to dissipate static charges.

ORDERING INFORMATION

REPLACEMENT BAGS AND FILTERS

AV-2 SERIES

- AV-2H HEPA filter (99.97% UL) - 2 gallon - 1 ea.
- AV-2B Paper recovery bags - 2 gallon - 5/package
- AV-5I Intermediate filter - 2 gallon - 2 pkg.

AV-5 SERIES

- AV-5H HEPA Filter (99.97% UL) - 5 gallon - 1 ea.
- AV-5B Paper Recovery Bags - 5 gallon - 5/package
- AV-5I Intermediate Filter - 2/package - fits AV-5 & 2 series

AV-15 & AV-55 SERIES

- AV-15H HEPA filter (99.97% UL) - 15 gallon - fits AV-15 & 55 series
- AV-15B Paper recovery bags - 15 gallon - 5/package
- AV-15I Intermediate filter - 15 gallon-2/package - fits AV-15 & AV-55 series

ACCESSORIES

- AV-5WP 5 gallon auto shut-off assembly for water pick-up
- AV-15WP 15 gallon auto shut-off assembly for water pick-up use (fits 55 gallon version)
- AV-650 Poly tool for water pick-up on polyethylene - adjustable roller wheels
- AV-H10 Extension Hose - 1 1/2" - 10 ft. w/cuff
- AV-H50 Extension hose - 1 1/2" 50 ft. w/cuff
- AV-HC-1 Hose to hose coupler - 1 1/2"
- AV-HN10 Neoprene extension hose - 10 ft. - 1 1/2"
- AV-C1 Hose cuff - 1 1/2"
- AV-103 11" plastic crevice tool - 1 1/2"
- AV-100 Curved steel wand - 5 foot - 1 1/2"
- AV-6200 Floor brush - 13" - 1 1/2"
- AV-6203 Water squeegee tool - 14" - 1 1/2"
- AV-102 Carpet tool - 14" - 1 1/2"
- AV-101 Inlet swivel connector - 1 1/2"
- AV-105 Goose neck hose adaptor for 55 gallon drum lid - 1 1/2"
- AV-3RB 3" Round brush - 1 1/2" connector plastic
- AV-31AB 2" x 54" aluminum wand - straight
- AV-314 2" aluminum floor tool
- AV-90317 2"x22" squeegee floor tool for water pick-up
- AV-208 2"x15" crevice tool - plastic
- AV-HC-2 Hose-to-hose coupler - 2"
- AV-C2 Hose cuff - 2"
- AV-2360 2" inlet swivel connector
- AV-H10-2 2" extension hose - 10 ft. w/cuffs
- AV-H50-2 2" extension hose - 50 ft. w/cuffs
- AV-906C 9" Rubber blower nozzle - 1 1/2"

Warranty Disclaimer

Air Systems' manufactured equipment is warranted to the original user against defects in workmanship or materials under normal use for one year after date of purchase. Any part which is determined by Air Systems to be defective in material or workmanship will be, as the exclusive remedy, repaired or replaced at Air Systems' option. This warranty does not apply to electrical systems or electronic components. Electrical parts are warranted, to the original user, for 90 days from the date of sale. During the warranty period, electrical components will be repaired or replaced at Air Systems' option.

NO OTHER WARRANTY, EXPRESSED OR IMPLIED, AS TO DESCRIPTION, QUALITY, MERCHANTABILITY, FITNESS FOR A PARTICULAR PURPOSE, OR ANY OTHER MATTER IS GIVEN BY AIR SYSTEMS IN CONNECTION HEREWITH. UNDER NO CIRCUMSTANCES SHALL THE SELLER BE LIABLE FOR LOSS OF PROFITS, ANY OTHER DIRECT OR INDIRECT COSTS, EXPENSES, LOSSES OR DAMAGES ARISING OUT OF DEFECTS IN, OR FAILURE OF THE PRODUCT OR ANY PART THEREOF.

The purchaser shall be solely responsible for compliance with all applicable Federal, State and Local OSHA and/or MSHA requirements. Although Air Systems International believes that its products, if operated and maintained as shipped from the factory and in accordance with our "operations manual", conform to OSHA and/or MSHA requirements, there are no implied or expressed warranties of such compliance extending beyond the limited warranty described herein. Product designs and specifications are subject to change without notice. **Rev 2 12/98**

Air leaks are not covered under warranty except when they result from a defective system component, i.e. an on/off valve or regulator or upon initial delivery due to poor workmanship. Air leaks due to poor delivery or damage will be covered under delivery claims. Minor air leaks are part of routine service and maintenance and are the responsibility of the customer just as are filters and oil changes.