

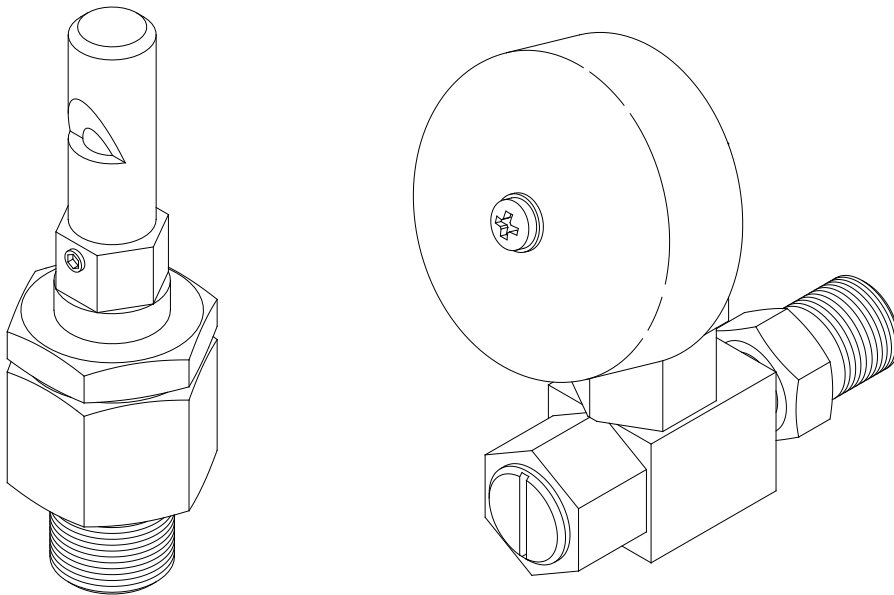

## **INSTALLATION AND OPERATING INSTRUCTIONS**

### **Models: AC-PA25 and AC-PA25B Low Pressure Whistle/Bell**



#### **WARNING**

This manual must be read carefully and followed by all persons who have or will have the responsibility for using or servicing this equipment. This equipment will perform as designed only if used according to the instructions. Otherwise it could fail to perform as designed, causing personal injury or death.

**Do NOT overtighten when installing alarm.  
Please read instructions before installing new unit.**

#### **AIR SYSTEMS INTERNATIONAL, INC.**

829 Juniper Crescent, Chesapeake, Va, 23320

Telephone (757) 424-3967

Toll Free 1-800-866-8100

Fax No. (757) 424-5348

[www.airsystems.com](http://www.airsystems.com)

e-mail: [sales@airsystems.com](mailto:sales@airsystems.com)

## Overview

The AC-PA25 and AC-PA25B low pressure alarms are designed to alert workers when there is approximately 500 psi left in the breathing air cylinders being used. This will allow enough time for the workers to egress the area, cylinders to be changed, etc. The alarm is preset at our factory to approximately 500 psi.

### Model: AC-PA25 Pneumatic Whistle Alarm

#### IF THE WHISTLE SHOULD GET OUT OF ADJUSTMENT:

- Pressurize the system until the alarm sets itself around 800 psi.
- Loosen the lock nut.
- Turn whistle bushing 2-3 turns counterclockwise.
- Bleed system pressure to desired alarm set point.
- Turn whistle bushing clockwise until alarm sounds.
- Repressurize system and bleed down slowly to verify new alarm activation pressure.
- Holding whistle bushing in place, retighten locknut.

#### INSTALLING WHISTLE:

**DO NOT** overtighten as damage to the unit will occur. Wrap 1/4" MPT end with thread sealing tape. Install whistle on the unregulated high pressure side (6000 psi max) of the system. As pressure decreases to approximately 500 psi the whistle will begin to sound. When pressure is applied, the whistle will sound until pressure reaches approximately 800 psi and the whistle seats.

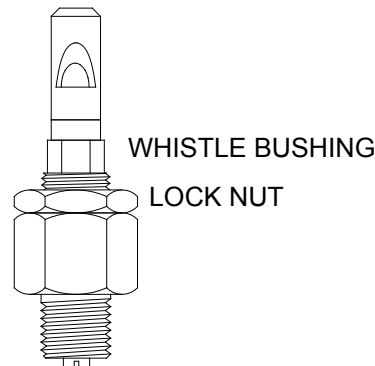

### Model: AC-PA25B Pneumatic Bell Alarm

#### IF THE BELL SHOULD GET OUT OF ADJUSTMENT:

- Pressurize the system until the alarm sets itself around 1000 psi.
- Bleed system pressure to desired alarm set point.
- Turn adjustment screw until bell sounds. Clockwise increases set point, counterclockwise decreases set point.
- Repressurize system and bleed down slowly to verify new alarm activation pressure.

#### INSTALLING BELL:

**DO NOT** overtighten as damage to the unit will occur. Wrap 1/4" MPT end with thread sealing tape. Install bell on the unregulated high pressure side (6000 psi max) of the system. As pressure decreases to approximately 500 psi the bell will begin to sound. When pressure is applied, the bell will sound until pressure reaches approximately 1000 psi and the bell seats.

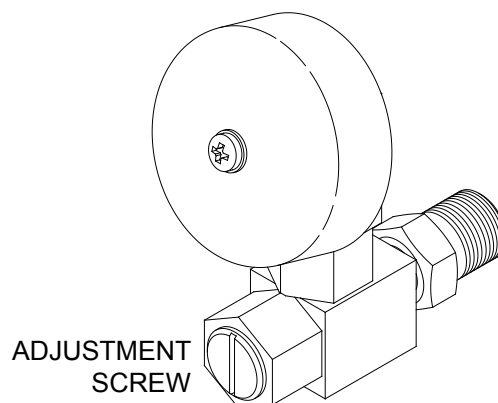

## WARRANTY

normal use for one year from the date of purchase. Any part which is determined by Air Systems to be defective in material or workmanship will be, as the exclusive remedy, repaired or replaced at Air Systems' option. This warranty does not apply to electrical systems or electronic components. Electrical parts are warranted, to the original user, for 90 days from the date of sale. During the warranty period, electrical components will be repaired or replaced at Air Systems' option.

**NO OTHER WARRANTY, EXPRESSED OR IMPLIED, AS TO DESCRIPTION, QUALITY, MERCHANTABILITY, FITNESS FOR A PARTICULAR PURPOSE, OR ANY OTHER MATTER IS GIVEN BY AIR SYSTEMS IN CONNECTION HERewith. UNDER NO CIRCUMSTANCES SHALL THE SELLER BE LIABLE FOR LOSS OF PROFITS, ANY OTHER DIRECT OR INDIRECT COSTS, EXPENSES, LOSSES, OR DAMAGES ARISING OUT OF DEFECTS IN, OR FAILURE OF THE PRODUCT OR ANY PART THEREOF.**

The purchaser shall be solely responsible for compliance with all applicable Federal, State and Local OSHA and/or MSHA requirements. Although Air Systems International believes that its products, if operated and maintained as shipped from the factory and in accordance with our "operations manual", conform to OSHA and/or MSHA requirements, there are no implied or expressed warranties of such compliance extending beyond the limited warranty described herein. Product designs and specifications are subject to change without notice. Rev. 2, 12/98

Air leaks are not covered under warranty except when they result from a defective system component, i.e. an on/off valve or regulator or upon initial delivery due to poor workmanship. Air leaks due to poor delivery or damage will be covered under delivery claims. Minor air leaks are part of routine service and maintenance and are the responsibility of the customer just as are filters and oil changes.

