



# OPERATING MANUAL

## MODELS:

**POA-2HP**

**POA-2HPB**

**POA-4HP**

**POA-4HPB**

**POA-6HP**

**POA-6HPB**

**POA-8HP**

**POA-8HPB**

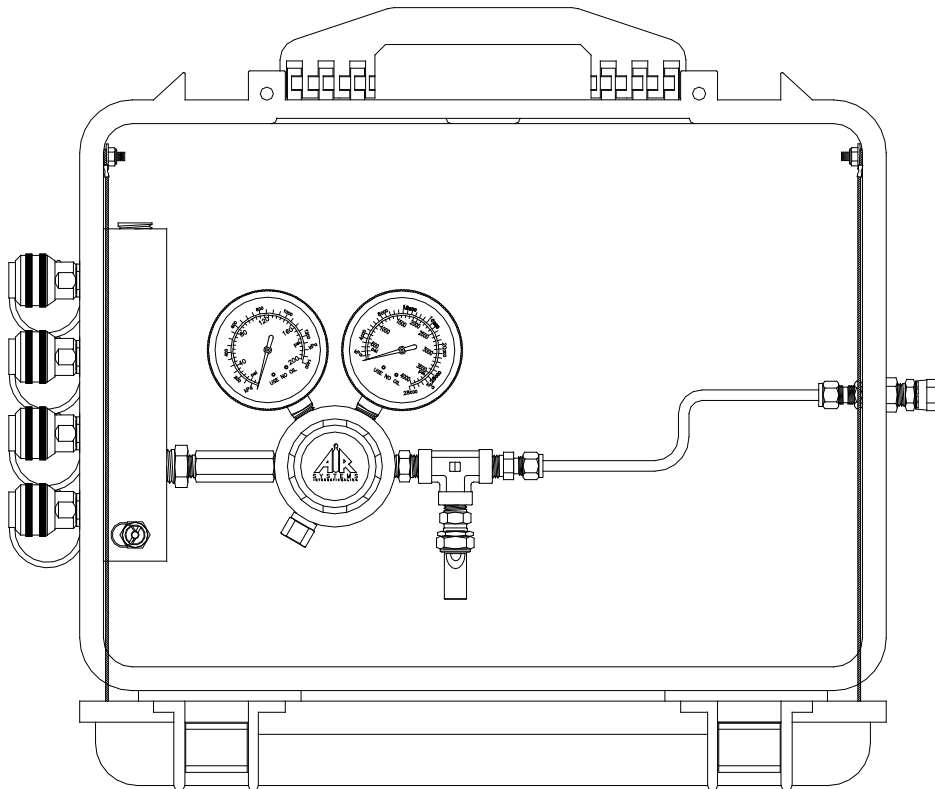

## **AIR SYSTEMS INTERNATIONAL, INC.**

829 Juniper Crescent, Chesapeake, Va, 23320

Telephone (757) 424-3967

Toll Free 1-800-866-8100

Fax No. (757) 424-5348

<http://www.airsystems.com>

e-mail: [sales@airsystems.com](mailto:sales@airsystems.com)

## SPECIFICATIONS

Inlet Connection	1/4" FPT 5000 PSI Maximum
Pressure Regulator	5000 PSI Max. Inlet Pressure/ 125 PSI Max. Outlet Pressure
Relief Valve	125 PSI
Low Pressure Warning Alarm	Pneumatic Low Pressure Whistle or Low Pressure Bell Set @ 500 PSI
Intrinsically Safe	Yes, No Electronic Devices

## REPLACEMENT PARTS

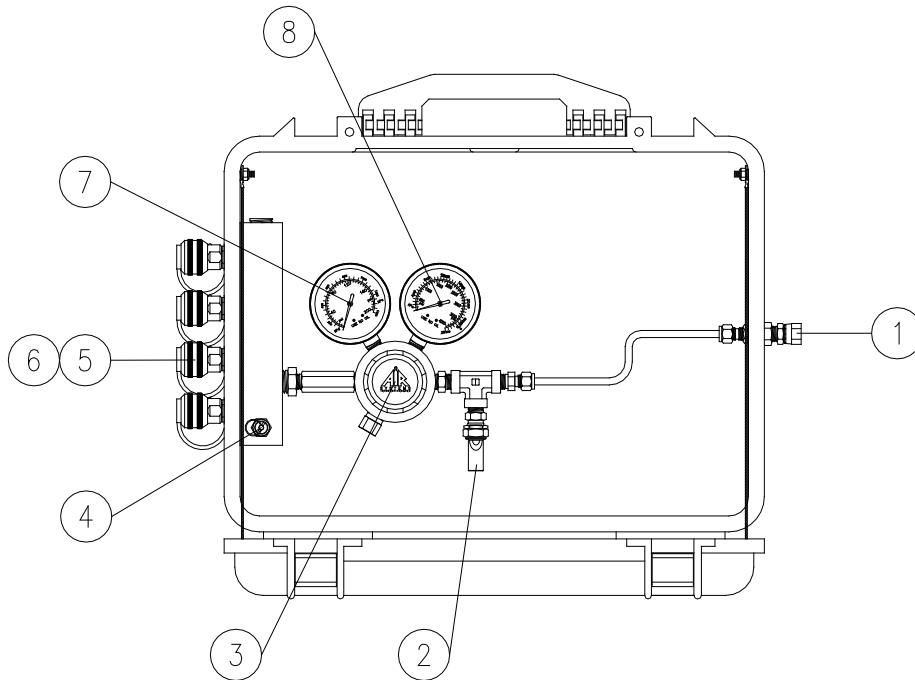

ITEM #	DESCRIPTION	PART #
1	1/4" FPT INLET FITTING	ST44MFV
2	LOW PRESSURE WHISTLE	AC-PA25
2A	LOW PRESSURE BELL (NOT SHOWN)	AC-PA25B
3	PRESSURE REGULATOR	REG-5000NG
4	125 PSI RELIEF VALVE	VR4125BR
5	HANSEN COUPLING	QDH3SL6M
5A	SCHRADER COUPLING	QDSSL6M
6	HANSEN DUST CAP	QDH3DCAP
6A	SCHRADER DUST CAP	QDSDCAP
7	OUTLET PRESSURE GAUGE	GA25200SRG
8	INLET PRESSURE GAUGE	GA256KSREG

## SETUP AND OPERATION

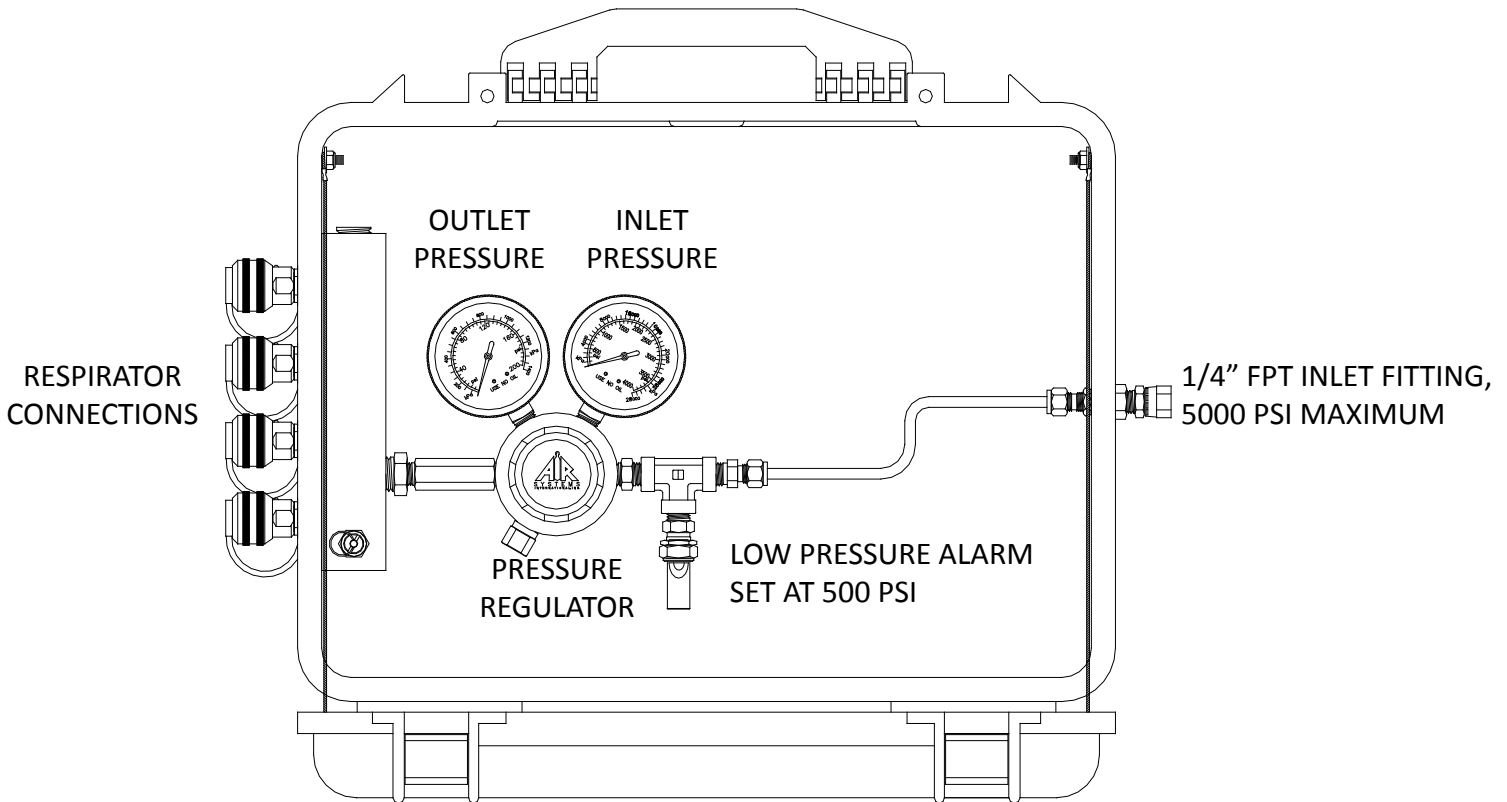

### STEP 1)

Connect the high pressure whip assembly (not included) from the cylinder bank to the 1/4" FPT inlet fitting.

### STEP 2)

Open one cylinder. At this time the low pressure warning alarm will sound until it sets itself at approximately 800 PSI for the whistle or approximately 1000 PSI for the bell (optional). Check reading on cylinder pressure gauge to verify that it is full. Close the cylinder valve.

### STEP 3)

Set the required respirator pressure with the regulator control knob. Turn the knob clockwise to increase pressure or counterclockwise to decrease pressure. Bleed pressure by partially engaging a male plug into one of the respirator connections while watching the cylinder pressure gauge. This depressurizes the regulator assembly simulating low pressure. The low pressure warning alarm will begin to sound at approximately 500 PSI.

### STEP 4)

If unsure, verify the other connected cylinders are full by repeating STEP 3.

### STEP 5)

Attach respirators and hoses to the respirator connections and readjust pressure regulator if necessary. The system is now operational.

## **WARRANTY DISCLAIMER**

Air Systems' manufactured equipment is warranted to the original user against defects in workmanship or materials under normal use for one year from the date of purchase. Any part which is determined by Air Systems to be defective in material or workmanship will be, as the exclusive remedy, repaired or replaced at Air Systems' option. This warranty does not apply to electrical systems or electronic components. Electrical parts are warranted, to the original user, for 90 days from the date of sale. During the warranty period, electrical components will be repaired or replaced at Air Systems' option.

**NO OTHER WARRANTY, EXPRESSED OR IMPLIED, AS TO DESCRIPTION, QUALITY, MERCHANTABILITY, FITNESS FOR A PARTICULAR PURPOSE, OR ANY OTHER MATTER IS GIVEN BY AIR SYSTEMS IN CONNECTION HERewith. UNDER NO CIRCUMSTANCES SHALL THE SELLER BE LIABLE FOR LOSS OF PROFITS, ANY OTHER DIRECT OR INDIRECT COSTS, EXPENSES, LOSSES, OR DAMAGES ARISING OUT OF DEFECTS IN, OR FAILURE OF THE PRODUCT OR ANY PART THEREOF.**

The purchaser shall be solely responsible for compliance with all applicable Federal, State and Local OSHA and/or MSHA requirements. Although Air Systems International believes that its products, if operated and maintained as shipped from the factory and in accordance with our "operations manual", conform to OSHA and/or MSHA requirements, there are no implied or expressed warranties of such compliance extending beyond the limited warranty described herein. Product designs and specifications are subject to change without notice. **Rev. 2, 12/98**

Air leaks are not covered under warranty except when they result from a defective system component, i.e. an on/off valve or regulator or upon initial delivery due to poor workmanship. Air leaks due to poor delivery or damage will be covered under delivery claims. Minor air leaks are part of routine service and maintenance and are the responsibility of the customer just as are filters and oil changes.